

auto electrical parts

Technical Information Sheet

Part No. 0-097-46

Commercial All in 1 LED rear lamp 24V, left hand. Stop / tail / direction indicator / fog / reverse / reflector / side Interchangeable Modules. ECE approved. IP67.

Dimensions

l 438.9 x w 66.6 x h 152.5mm.



Technical Drawing (not to scale)

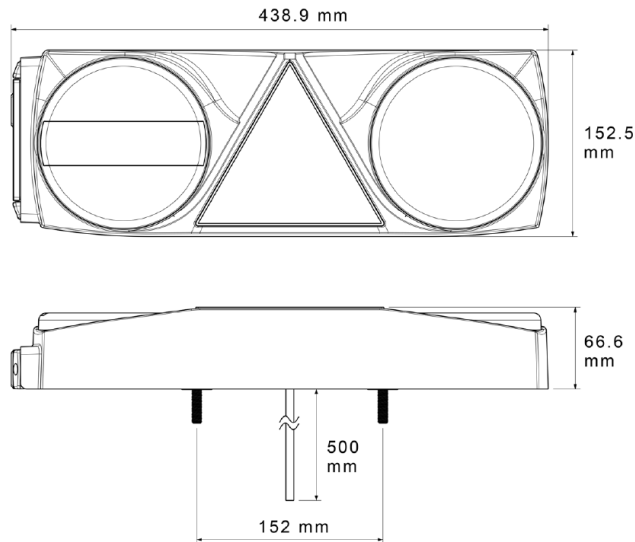

Specification

Type	Commercial LED rear lamp
Voltage	24v
Function	Stop/tail/direction indicator/fog/reflex reflector/side marker/reverse
Lens	Polycarbonate
IP Rating	IP67
Dimensions	l 438.9 x w 66.6 x h 152.5mm
Compliance	ECE

The information contained in this document is correct to the best of our knowledge at the time of printing. However, specifications may change at any time without notice.